

FICHE D'HOMOLOGATION / HOMOLOGATION FORM

005-BR-30



COMMISSION
INTERNATIONALE
DE KARTING - FIA



PROTECTION DES ROUES ARRIERE / REAR WHEEL PROTECTION

Constructeur / <i>Manufacturer</i>	Righetti Ridolfi
Marque / <i>Make</i>	Righetti Ridolfi
Modèle / <i>Model</i>	XTR22
Catégorie / <i>Category</i>	Group 1 & 2
Durée de l'homologation / <i>Validity of the Homologation</i>	2 ans / 2 years
Nombre de pages / <i>Number of pages</i>	4
La présente Fiche d'Homologation reproduit descriptions, illustrations et dimensions de la protection des roues arrière au moment de l'homologation CIK-FIA.	<i>This Homologation Form reproduces descriptions, illustrations and dimensions of the rear wheel protection at the moment of the CIK-FIA homologation.</i>



Photo vue arrière de la protection avec supports / *Photo of the rear of the protection with supports*

**Signature et tampon de l'ASN /
Signature and stamp of the ASN**

**Signature et tampon de la CIK-FIA /
Signature and stamp of the CIK-FIA**

Photo vue de dessus avec supports / *Photo from above with supports*



Photo vue de côté avec supports / *Photo from the side with supports*

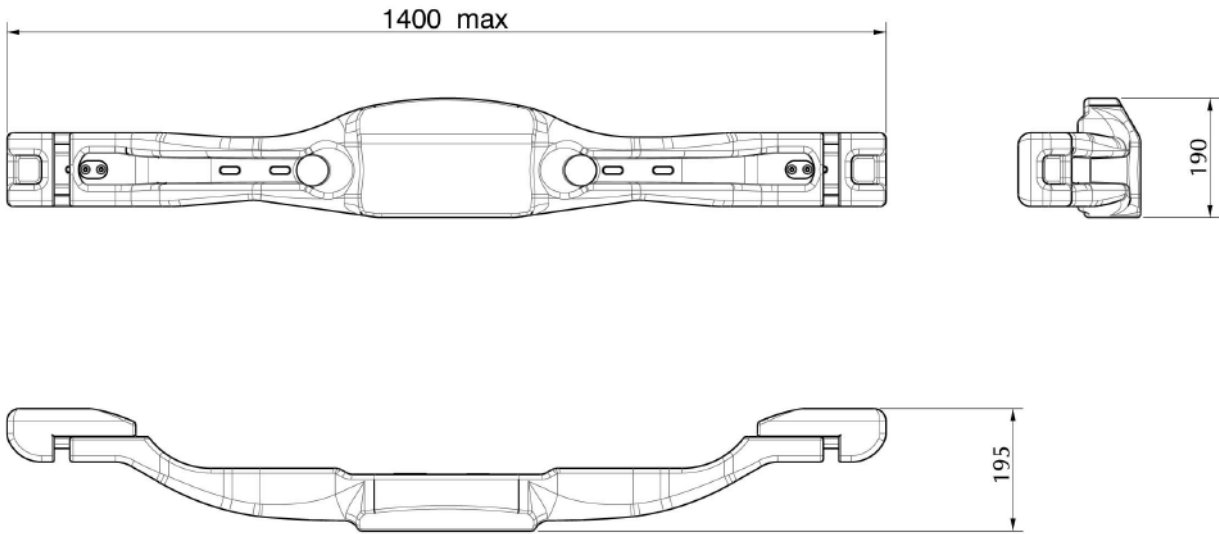

A	Cotes / Dimensions	
Protection des roues arrière sans supports / Rear wheel protection without supports		
Dessin technique (Dimensions d'encombrement) / Technical drawing (Main external dimensions)		
Protection seule masse en grammes / Protection only mass in grammes	2000 g	± 10 %
		

B	Supports de fixation / Attachment supports	
Dessin technique explosé / Exploded technical drawing		
Support masse en grammes / Support mass in grammes	760 g	± 5 %
		

C

**Photo du marquage du numéro d'homologation et logo CIK-FIA /
Photo of marking of homologation number and CIK-FIA logo**

Eléments plastiques de la protection arrière / *Rear protection plastic parts*



Supports / *Supports*



**Le marquage et le numéro d'homologation doivent rester clairement visibles en permanence. /
The marking and the homologation number must remain clearly visible permanently.**