

FICHE D'HOMOLOGATION / HOMOLOGATION FORM

005-BS-20



COMMISSION
INTERNATIONALE
DE KARTING - FIA



CARROSSERIE LATERALE / SIDE BODYWORK

Constructeur / <i>Manufacturer</i>	RIGHETTI RIDOLFI
Marque / <i>Make</i>	RIGHETTI RIDOLFI
Modèle / <i>Model</i>	XTR22
Catégorie / <i>Category</i>	Group 1 & 2
Durée de l'homologation / <i>Validity of the Homologation</i>	2 ans / 2 years
Nombre de pages / <i>Number of pages</i>	4
La présente Fiche d'Homologation reproduit descriptions, illustrations et dimensions de la carrosserie latérale au moment de l'homologation CIK-FIA.	<i>This Homologation Form reproduces descriptions, illustrations and dimensions of the side bodywork at the moment of the CIK-FIA homologation.</i>



Photo vue de côté de la carrosserie latérale / *Photo of the side of the bodywork*

Signature et tampon de l'ASN / <i>Signature and stamp of the ASN</i>	Signature et tampon de la CIK-FIA / <i>Signature and stamp of the CIK-FIA</i>

Photo vue de dessus avec supports / *Photo from above with supports*

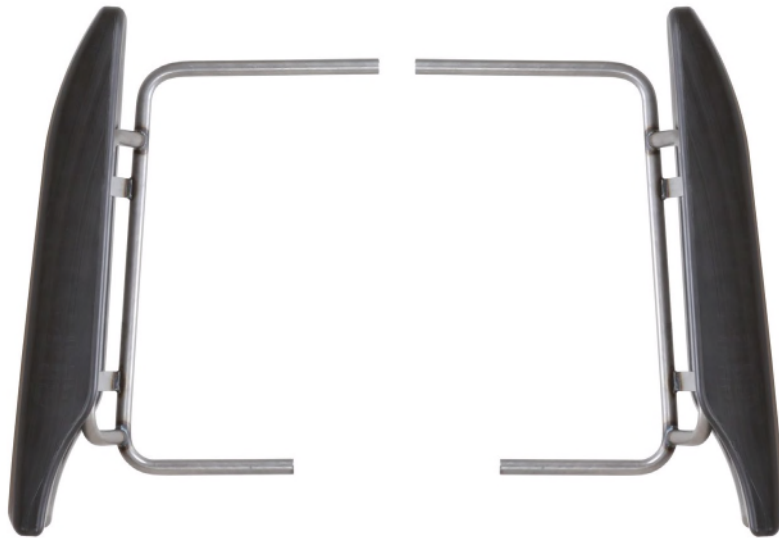
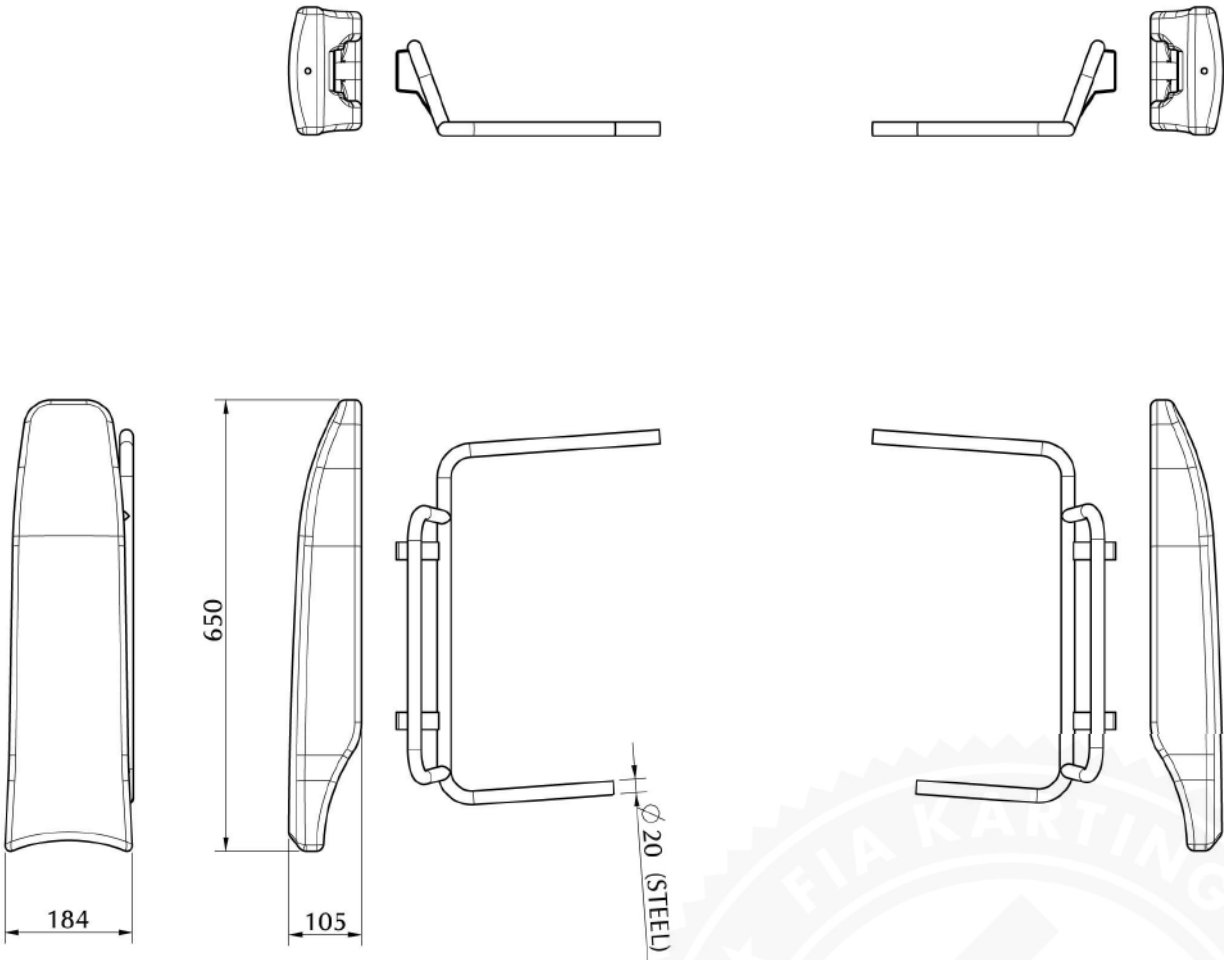

Photo vue de devant avec supports / *Photo from the front with supports*



A	Cotes / Dimensions	
Carrosserie latérale avec supports / Side bodywork with supports		
Dessin technique (Dimensions d'encombrement/Matériau, diamètre et épaisseur des supports) / Technical drawing (Fairing main external dimensions/Material, diameter and wall thickness of supports)		
Carrosserie (droite ou gauche seule) masse en grammes <i>Bodywork (RH or LH only) mass in grammes</i>	660 g	$\pm 10 \%$
Support (droit ou gauche seul) masse en grammes <i>Support (RH or LH only) mass in grammes</i>	1230 g	$\pm 5 \%$
		

D

**Photo du marquage du numéro d'homologation et logo CIK-FIA /
Photo of marking of homologation number and CIK-FIA logo**

Eléments plastiques de la carrosserie latérale / *Lateral bodywork plastic parts*



Supports / *Supports*



**Le marquage et le numéro d'homologation doivent rester clairement visibles en permanence. /
The marking and the homologation number must remain clearly visible permanently.**